



MASTER
NEXT GENERATION



Unità carrellata per l'aspirazione e la filtrazione di fumi di saldatura. Dotata di braccio articolato da 3 mt e di una batteria di filtri ad azione meccanica per filtrare e deodorare i fumi aspirati prima della reimmissione in ambiente. Disponibile nella versione con un braccio da 150 mm, 200 mm o due bracci da 150 mm.



A trolley mounted unit for extracting and filtering welding fumes. Equipped with a 3 m articulated arm and a battery of mechanical filters that filter and deodorise the fumes before they are recycled into the environment. Available with a 150 mm and a 200 mm arm, or 2 x 150 mm arms.



Unité mobile pour l'aspiration et la filtration de fumées de soudure. Équipée de bras articulé de 3 m et d'une batterie de filtres à action mécanique pour filtrer et désodoriser les fumées aspirées avant leur réémission dans l'atmosphère. Disponible en version à un bras de 150 mm, 200 mm ou deux bras de 150 mm.



Fahrbare Einheit für das Absaugen und Filtern von Schweißrauch. Ausgestattet mit 3 m Gelenkarm und einer mechanisch wirkenden Filterbatterie zur Filterung und Geruchsverbesserung der Rauche, bevor diese wieder in den Raum zurückgeführt werden. Verfügbar in der Version mit 150 mm, 200 mm Arm oder zwei 150 mm Armen.



Unidad móvil para aspirar y filtrar humos de soldadura. Equipada con brazo articulado de 3 m y batería de filtros de acción mecánica para filtrar y desodorizar los humos aspirados antes de liberarlos en el ambiente. Disponible versión con brazo de 150 mm o 200 mm, o dos brazos de 150 mm.

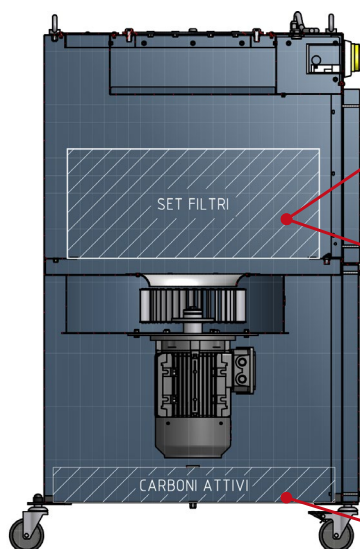

MASTER-NG/CART: 2xCELLULOSE Ø350 - H300 - EN 60335-2-69 - Class M

MASTER-NG/CART-P: 2xPOLYESTER Ø350 - H300 - EN 60335-2-69 - Class M

MASTER-NG/CAR-HEPA: 2xPOLYESTER HEPA Ø350 - H300 - EN 1822 - Class H13

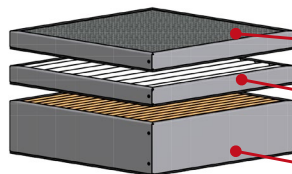

MASTER-NG/RIPM: PREFILTRO METALLICO / METAL PREFILTER

MASTER-NG/RPS: PREFILTRO SINTETICO / PREFILTER

MASTER-NG/RIF: FILTRO ALTA EFFICIENZA / HIGH EFFICIENCY FILTER

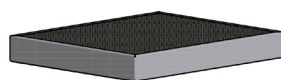

MASTER-NG/CONT: FILTRO A CARBONI ATTIVI / CARBON FILTER 16 Kg

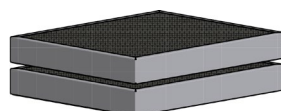

MASTER-NG/CONT X 2: FILTRO A CARBONI ATTIVI / CARBON FILTER 32 Kg

Model		%	m ²		Carb. Kg	Carb. Lbs		cert	
MASTER-NG-1BR	1.600 m ³ /h - 882 c.f.m.	95	2,75	147 kg - 324 lb	16	35,28	400 V - 50 Hz - 3ph (3p+T)	CE	3 Hp - 2,2 kW
MASTER-NG-2BR	2.500 m ³ /h - 1470 c.f.m.	95	2,75	172 kg - 380 lb	16	35,28	400 V - 50 Hz - 3ph (3p+T)	CE	3 Hp - 2,2 kW
MASTER-NG-200	2.000 m ³ /h - 1176 c.f.m.	95	2,75	148 kg - 326 lb	16	35,28	400 V - 50 Hz - 3ph (3p+T)	CE	3 Hp - 2,2 kW
MASTER-NG-1BR-CARB	1.600 m ³ /h - 882 c.f.m.	90	0,6	158 kg - 348 lb	32	70,55	400 V - 50 Hz - 3ph (3p+T)	CE	3 Hp - 2,2 kW
MASTER-NG-2BR-CARB	2.500 m ³ /h - 1470 c.f.m.	90	0,6	183 kg - 403 lb	32	70,55	400 V - 50 Hz - 3ph (3p+T)	CE	3 Hp - 2,2 kW
MASTER-NG-200-CARB	2.000 m ³ /h - 1176 c.f.m.	90	0,6	159 kg - 350 lb	32	70,55	400 V - 50 Hz - 3ph (3p+T)	CE	3 Hp - 2,2 kW
MASTER-NG-1BR-C	1.600 m ³ /h - 882 c.f.m.	99,9	18	135 kg - 297 lb	-	-	400 V - 50 Hz - 3ph (3p+T)	CE	3 Hp - 2,2 kW
MASTER-NG-2BR-C	2.500 m ³ /h - 1470 c.f.m.	99,9	18	160 kg - 352 lb	-	-	400 V - 50 Hz - 3ph (3p+T)	CE	3 Hp - 2,2 kW
MASTER-NG-200-C	2.000 m ³ /h - 1176 c.f.m.	99,9	18	136 kg - 300 lb	-	-	400 V - 50 Hz - 3ph (3p+T)	CE	3 Hp - 2,2 kW
MASTER-NG-1BR-C-16CA	1.600 m ³ /h - 882 c.f.m.	99,9	18	151 kg - 332 lb	16	35,28	400 V - 50 Hz - 3ph (3p+T)	CE	3 Hp - 2,2 kW
MASTER-NG-2BR-C-16CA	2.500 m ³ /h - 1470 c.f.m.	99,9	18	176 kg - 388 lb	16	35,28	400 V - 50 Hz - 3ph (3p+T)	CE	3 Hp - 2,2 kW
MASTER-NG-200-C-16CA	2.000 m ³ /h - 1176 c.f.m.	99,9	18	152 kg - 335 lb	16	35,28	400 V - 50 Hz - 3ph (3p+T)	CE	3 Hp - 2,2 kW
MASTER-NG-1BR-C-32CA	1.600 m ³ /h - 882 c.f.m.	99,9	18	167 kg - 368 lb	32	70,55	400 V - 50 Hz - 3ph (3p+T)	CE	3 Hp - 2,2 kW
MASTER-NG-2BR-C-32CA	2.500 m ³ /h - 1470 c.f.m.	99,9	18	192 kg - 423 lb	32	70,55	400 V - 50 Hz - 3ph (3p+T)	CE	3 Hp - 2,2 kW
MASTER-NG-200-C-32CA	2.000 m ³ /h - 1176 c.f.m.	99,9	18	168 kg - 370 lb	32	70,55	400 V - 50 Hz - 3ph (3p+T)	CE	3 Hp - 2,2 kW
MASTER-NG-1BR-32CA	1.600 m ³ /h - 882 c.f.m.	95	2,75	147 kg - 324 lb	32	70,55	400 V - 50 Hz - 3ph (3p+T)	CE	3 Hp - 2,2 kW
MASTER-NG-2BR-32CA	2.500 m ³ /h - 1470 c.f.m.	95	2,75	172 kg - 380 lb	16	70,55	400 V - 50 Hz - 3ph (3p+T)	CE	3 Hp - 2,2 kW
MASTER-NG-200-32CA	2.000 m ³ /h - 1176 c.f.m.	95	2,75	148 kg - 326 lb	16	70,55	400 V - 50 Hz - 3ph (3p+T)	CE	3 Hp - 2,2 kW
MASTER-NG-1BR-C/P	1.600 m ³ /h - 882 c.f.m.	99,9	18	135 kg - 297 lb	-	-	400 V - 50 Hz - 3ph (3p+T)	CE	3 Hp - 2,2 kW
MASTER-NG-2BR-C/P	2.500 m ³ /h - 1470 c.f.m.	99,9	18	160 kg - 352 lb	-	-	400 V - 50 Hz - 3ph (3p+T)	CE	3 Hp - 2,2 kW
MASTER-NG-200C/P	2.000 m ³ /h - 1176 c.f.m.	99,9	18	136 kg - 300 lb	-	-	400 V - 50 Hz - 3ph (3p+T)	CE	3 Hp - 2,2 kW
MASTER-NG-1BR-C/P-16CA	1.600 m ³ /h - 882 c.f.m.	99,9	18	151 kg - 332 lb	16	35,28	400 V - 50 Hz - 3ph (3p+T)	CE	3 Hp - 2,2 kW
MASTER-NG-2BR-C/P-16CA	2.500 m ³ /h - 1470 c.f.m.	99,9	18	176 kg - 388 lb	16	35,28	400 V - 50 Hz - 3ph (3p+T)	CE	3 Hp - 2,2 kW
MASTER-NG-200C/P-16CA	2.000 m ³ /h - 1176 c.f.m.	99,9	18	152 kg - 335 lb	16	35,28	400 V - 50 Hz - 3ph (3p+T)	CE	3 Hp - 2,2 kW
MASTER-NG-1BR-C/P-32CA	1.600 m ³ /h - 882 c.f.m.	99,9	18	167 kg - 368 lb	32	70,55	400 V - 50 Hz - 3ph (3p+T)	CE	3 Hp - 2,2 kW
MASTER-NG-2BR-C/P-32CA	2.500 m ³ /h - 1470 c.f.m.	99,9	18	192 kg - 423 lb	32	70,55	400 V - 50 Hz - 3ph (3p+T)	CE	3 Hp - 2,2 kW
MASTER-NG-200C/P-32CA	2.000 m ³ /h - 1176 c.f.m.	99,9	18	168 kg - 370 lb	32	70,55	400 V - 50 Hz - 3ph (3p+T)	CE	3 Hp - 2,2 kW
MASTER-NG-1BR-HEPA	1.600 m ³ /h - 882 c.f.m.	99,95	18	135 kg - 297 lb	-	-	400 V - 50 Hz - 3ph (3p+T)	CE	3 Hp - 2,2 kW
MASTER-NG-2BR-HEPA	2.500 m ³ /h - 1470 c.f.m.	99,95	18	160 kg - 352 lb	-	-	400 V - 50 Hz - 3ph (3p+T)	CE	3 Hp - 2,2 kW
MASTER-NG-200-HEPA	2.000 m ³ /h - 1176 c.f.m.	99,95	18	136 kg - 300 lb	-	-	400 V - 50 Hz - 3ph (3p+T)	CE	3 Hp - 2,2 kW
MASTER-NG-1BR-HEPA-16CA	1.600 m ³ /h - 882 c.f.m.	99,95	18	151 kg - 332 lb	16	35,28	400 V - 50 Hz - 3ph (3p+T)	CE	3 Hp - 2,2 kW
MASTER-NG-2BR-HEPA-16CA	2.500 m ³ /h - 1470 c.f.m.	99,95	18	176 kg - 388 lb	16	35,28	400 V - 50 Hz - 3ph (3p+T)	CE	3 Hp - 2,2 kW
MASTER-NG-200-HEPA-16CA	2.000 m ³ /h - 1176 c.f.m.	99,95	18	152 kg - 335 lb	16	35,28	400 V - 50 Hz - 3ph (3p+T)	CE	3 Hp - 2,2 kW
MASTER-NG-1BR-HEPA-32CA	1.600 m ³ /h - 882 c.f.m.	99,95	18	167 kg - 368 lb	32	70,55	400 V - 50 Hz - 3ph (3p+T)	CE	3 Hp - 2,2 kW
MASTER-NG-2BR-HEPA-32CA	2.500 m ³ /h - 1470 c.f.m.	99,95	18	192 kg - 423 lb	32	70,55	400 V - 50 Hz - 3ph (3p+T)	CE	3 Hp - 2,2 kW
MASTER-NG-200-HEPA-32CA	2.000 m ³ /h - 1176 c.f.m.	99,95	18	168 kg - 370 lb	32	70,55	400 V - 50 Hz - 3ph (3p+T)	CE	3 Hp - 2,2 kW

Tabella filtri - Filter table - Tableau des filtres - Tabelle filtern - Tabla de filtros

MODELLO	MASTER-NG/RIPM	MASTER-NG/RIPS	MASTER-NG/RIF	MASTER-NG/CART (x2)	MASTER-NG/CART-P (x2)	MASTER-NG/CART-HEPA (x2)	MASTER-NG/CONT	MASTER-NG/CONT (x2)
MASTER-NG-1BR	✓	✓	✓	✗	✗	✗	✓	✗
MASTER-NG-2BR	✓	✓	✓	✗	✗	✗	✓	✗
MASTER-NG-200	✓	✓	✓	✗	✗	✗	✓	✗
MASTER-NG-1BR-32CA	✓	✓	✓	✗	✗	✗	✗	✓
MASTER-NG-2BR-32CA	✓	✓	✓	✗	✗	✗	✗	✓
MASTER-NG-200-32CA	✓	✓	✓	✗	✗	✗	✗	✓
MASTER-NG-1BR-CARB	✓	✓	✗	✗	✗	✗	✗	✓
MASTER-NG-2BR-CARB	✓	✓	✗	✗	✗	✗	✗	✓
MASTER-NG-200-CARB	✓	✓	✗	✗	✗	✗	✗	✓
MASTER-NG-1BR-C	✗	✗	✗	✓	✗	✗	✗	✗
MASTER-NG-2BR-C	✗	✗	✗	✓	✗	✗	✗	✗
MASTER-NG-200-C	✗	✗	✗	✓	✗	✗	✗	✗
MASTER-NG-1BR-C-16CA	✗	✗	✗	✓	✗	✗	✓	✗
MASTER-NG-2BR-C-16CA	✗	✗	✗	✓	✗	✗	✓	✗
MASTER-NG-200-C-16CA	✗	✗	✗	✓	✗	✗	✓	✗
MASTER-NG-1BR-C-32CA	✗	✗	✗	✓	✗	✗	✗	✓
MASTER-NG-2BR-C-32CA	✗	✗	✗	✓	✗	✗	✗	✓
MASTER-NG-200-C-32CA	✗	✗	✗	✓	✗	✗	✗	✓
MASTER-NG-1BR-C/P	✗	✗	✗	✗	✓	✗	✗	✗
MASTER-NG-2BR-C/P	✗	✗	✗	✗	✓	✗	✗	✗
MASTER-NG-200-C/P	✗	✗	✗	✗	✓	✗	✗	✗
MASTER-NG-1BR-C/P-16CA	✗	✗	✗	✗	✓	✗	✓	✗
MASTER-NG-2BR-C/P-16CA	✗	✗	✗	✗	✓	✗	✓	✗
MASTER-NG-200-C/P-16CA	✗	✗	✗	✗	✓	✗	✓	✗
MASTER-NG-1BR-C/P-32CA	✗	✗	✗	✗	✓	✗	✗	✓
MASTER-NG-2BR-C/P-32CA	✗	✗	✗	✗	✓	✗	✗	✓
MASTER-NG-200-C/P-32CA	✗	✗	✗	✗	✓	✗	✗	✓
MASTER-NG-1BR-HEPA	✗	✗	✗	✗	✗	✓	✗	✗
MASTER-NG-2BR-HEPA	✗	✗	✗	✗	✗	✓	✗	✗
MASTER-NG-200-HEPA	✗	✗	✗	✗	✗	✓	✗	✗
MASTER-NG-1BR-HEPA-16CA	✗	✗	✗	✗	✗	✓	✓	✗
MASTER-NG-2BR-HEPA-16CA	✗	✗	✗	✗	✗	✓	✓	✗
MASTER-NG-200-HEPA-16CA	✗	✗	✗	✗	✗	✓	✓	✗
MASTER-NG-1BR-HEPA-32CA	✗	✗	✗	✗	✗	✓	✗	✓
MASTER-NG-2BR-HEPA-32CA	✗	✗	✗	✗	✗	✓	✗	✓
MASTER-NG-200-HEPA-32CA	✗	✗	✗	✗	✗	✓	✗	✓

Modelli - Models - Modèles - Modelle - Modelos



MASTER-NG-2BR

MASTER-NG-200

Dimensioni - Dimensions - Dimensions - Abmessungen - Dimensiones

